

ALPHAFIT



CORE LEG PRESS

1 | INNOVATIVE WALK-THROUGH DESIGN REDUCING RISK OF INJURY

The outdated leg press design of the bulky frame leads to a high probability that a user will trip while entering and exiting the machine. AlphaFit has engineered an innovative walk-through design making it easier to enter and exit, limiting the risk of athletes tripping if fatigued.

3 | PRESS SAFELY WITH THE DROP STOP'S EASY HEIGHT ADJUSTMENT SETTINGS

For peace of mind, the adjustable heavy-duty drop stop can be set at 6 different height settings in 50mm increments. For convenience, adjust the drop stop with either your hand or foot by simply pushing the drop stop up and away from you. This feature ensures each user will find a safe and comfortable base position for their lowest range of movement.

5 | LOAD WITH WEIGHT OR ADD RESISTANCE

The leg press trolley has a starting weight of 55kg and can be loaded with up to 900kg (225kg per pin). With four premium Storage Pins with Shoulder to protect your machine, you can keep your weights close by. Each pin offers 350mm of storage space and has a load rating of 250kg. In addition to the plate loaded trolley, users can incorporate resistance training by utilising power bands secured via the six band hooks on either side of the machine.

2 | GET COMFORTABLE AND FIND YOUR PERFECT POSITION WITH A WIDE SEAT AND FOOTPLATE

The Core Leg Press features a 500mm wide seat with lumbar support, to help promote good form and limit injuries. The seat pad position can be easily adjusted to either 30 or 40 degrees, using a foot pedal located at the side of the seat. The machine's large 800mm x 600mm footplate with non-slip coating allows users to maintain a strong grip throughout heavy lifting and ability to comfortably adjust their stance and form depending on the exercise.

4 | DESIGNED, ENGINEERED AND TESTED WITH SAFETY MEETING AESTHETICS

The Core Leg Press's heavy-duty design uses 40mm Linear rods for smooth operating motion and large load capacity. The machine covers and protects moving parts and eliminates any concern for users pinching fingers for both safety and aesthetics.

6 | PROUDLY MADE IN AUSTRALIA, CUSTOMISE TO BUILD THE LEG PRESS YOU'VE ALWAYS WANTED

The Core Leg Press is 100% Australian made allowing us to offer an unbeatable level of customisation including colour, branding and accessories. Part of the newest range of AlphaFit plate loaded machines, you can easily create the best strength setup for your unique space and training requirements.

Standard model pictured - Core Leg Press in Charcoal Grey. Custom configurations, colours and branding available.
Contact your sales representative for more information.



Learn more at alphafit.com.au/core-leg-press

ALPHAFIT

“

THIS IS SO MUCH MORE THAN YOUR AVERAGE LEG PRESS. DESIGNED AND ENGINEERED IN AUSTRALIA WITH PEAK PERFORMANCE AND AESTHETICS IN MIND, THIS PRODUCT IS GUARANTEED TO BE THE CENTREPIECE OF YOUR COMMERCIAL GYM, SPECIALTY STRENGTH OR REHAB FACILITY.

”

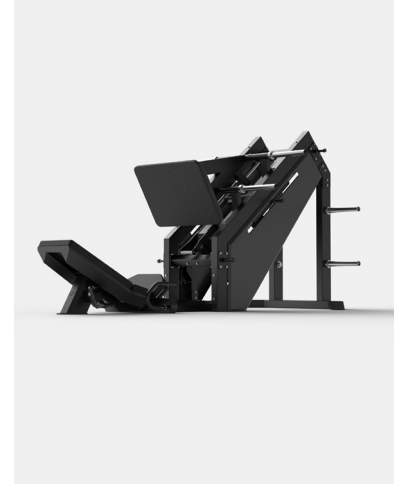
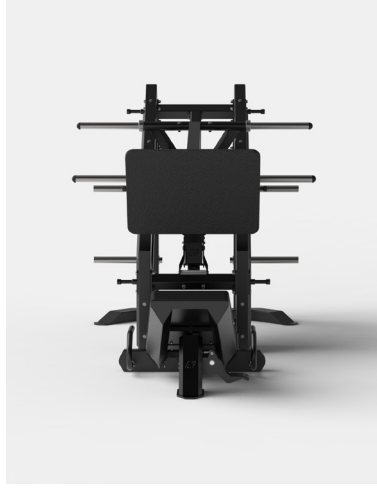

CORE LEG PRESS SPECIFICATIONS

Product Dimensions (L x W x H):	3015mm x 1500mm x 1655mm
Product Weight:	430kg
Unloaded Trolley Weight:	55kg
Trolley Pin Plate Capacity:	900kg (225kg of weight per pin)
Drop Stop Adjustments:	6 positions (50mm increments)
Warranty:	'Built Not Bought' warranty
Standard Colour Options:	Choose from 13 colours

